

TSG

3-SERIES

ORDER FORM

TROUGHING SUREGUIDE®

All Dimensions in mm

Date

Reference No.

Customer: _____
 Conveyor Number: _____
 Belt Type: _____
 Belt Speed: _____
 Tons/hour: _____

Min Temperature: _____ °C

Max Temperature: _____ °C

Commodity: _____

Series: Standard HD (Heavy Duty) UHD (Ultra Heavy Duty)

Lagging: Urethane Rubber Fras Rubber

Food Grade: No Wet Dry

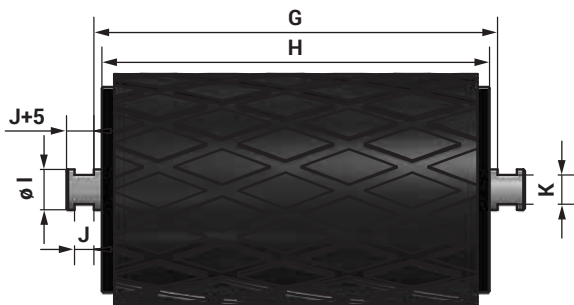
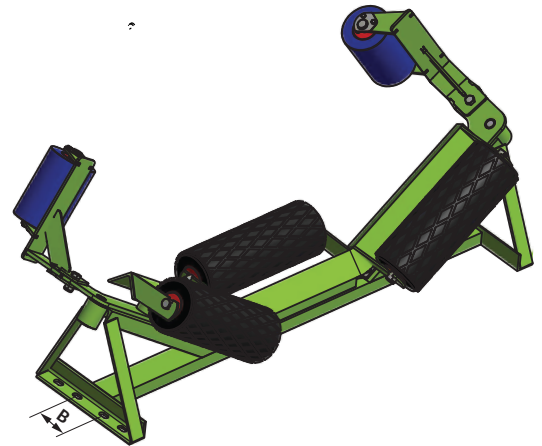
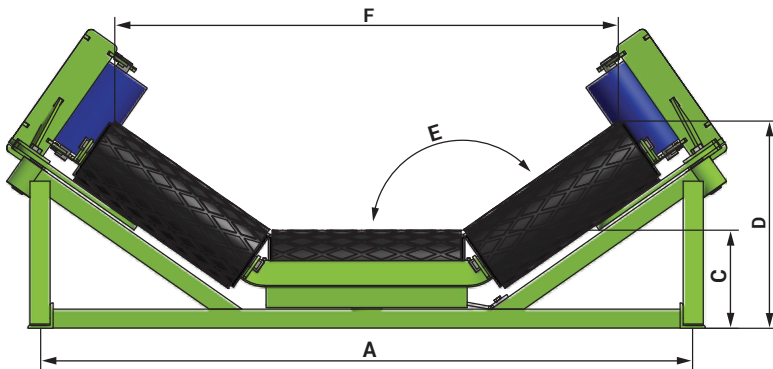

Measurements

A =		mm
B =		mm
C =		mm
D =		mm
E =		°

F =		mm
G =		mm
H =		mm
I =		mm
J =		mm
K =		mm

Additional Comments:

Approved By: _____
(Customer Name)

Signature: _____

Date: _____

SINCE 1992

WWW.SUREGUIDE.NET

SUREGUIDE®

SUPERIOR BELT TRACKING



T: +61 3 9753 5505 | E: sales@sureguide.com.au



T: +27 11 662 7900/1 | E: sales@sureguide.co.za